

Unit 10: Software Quality

Objective

- To introduce software quality management and assurance with particular reference to the requirements of ISO 9000 and associated standards.
- To introduce QFD, a technique to support quality engineering.

What is Quality?

- Quality = zero defects (Crosby)
- The totality of features and characteristics of a product or service that bear on its ability to satisfy specified or implied needs. (ISO)
- Quality = fitness for purpose (Juran)
- Quality n., the degree of excellence (OED)

Many Views of Quality

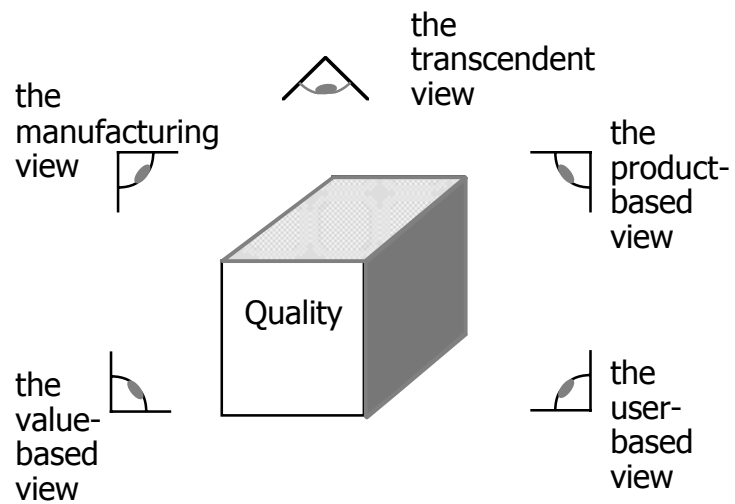

Quality Management System

- A Quality Management System is the organisational structure, responsibility, procedures, activities, capabilities and resources that together aim to ensure that software products will satisfy stated or implied needs.

Why Quality Management

- Quality Management reduces the cost of failure:
 - costs of correcting defects, both before and after delivery;
 - overruns against time and budget;
 - unnecessary high maintenance costs;
 - indirect costs which users incur due to poor quality software.

these figures are considered to be conservative

Survey data indicates that for a company with a turnover of £3m per year, failure costs are likely to be in the order of £600K or 20% of turnover, and saved costs due to implementing a quality management system are likely to be in the 25% – 50% of failure costs therefore saving £150K – £300K .

ISO 9000 and Associated Standards

- ISO 9000 Quality Management and Quality Assurance Standards - Guidelines for Selection and Use.
- ISO 9001 Quality Systems - Model for Quality Assurance in Design/Development, Production, Installation and Servicing.
- ISO 9004 Quality Management and Quality Systems Elements - Guidelines

↑
corresponding to EN 29001
& BS 5750 Part 1 (1987)

Perspective

- we will be looking at quality management primarily from a "supplier" perspective as distinct from a "purchaser" perspective
- however, software engineers may frequently find themselves on the purchaser side and will have to design their quality management system appropriately

Quality Policy

- "The suppliers management should define and document its policy and objectives for, and commitment to, quality. The supplier should ensure that this policy is understood, implemented and maintained at all levels in the organisation."

 **THIS IS VERY IMPORTANT!**

Quality System

- brings together the functions, objectives and activities that contribute to the product's or service's consistent quality...
- should be documented, generally in the form of a **quality manual**, which must be...
- appropriate, concise, practical, up-to-date, correspond to what really happens, distributed to all relevant staff, effectively implemented.

Organisation

- a complete organisation structure is required showing the duties, responsibilities and authority of all staff who manage verify or perform work affecting quality;
- a management representative, with defined responsibilities and authority, needs to be nominated who will be responsible for all matters affecting the quality system;
- staff responsible for the verification of any or all aspects of the quality system must be properly skilled and trained.

although this person acts as a focal point for quality matters the whole workforce contributes to the overall quality of the products or services

Management Review

- The quality management system will need to be reviewed at regular intervals by management to ensure its continuing suitability, effectiveness and conformance with ISO 9001.

Software Development

- A software development project should be organised according to one of several lifecycle models.
- Quality related activities should be planned and implemented with respect to the nature of the life-cycle model used.

Contract Review

Quality
Manual
Example

- The contract should be reviewed by the supplier to ensure that:
 - scope of contract and requirements are defined and documented
 - possible contingencies and risks are identified
 - proprietary information is adequately protected
 - any requirements differing from those of the tender are resolved
 - the supplier has the capability to meet contractual requirements
 - the suppliers responsibility with regard to subcontracted work is defined
 - the terminology is agreed by both parties

Contract Review

Quality
Manual
Example

- These items are frequently found to be relevant in the contract:
 - acceptance criteria
 - handling of changes in the purchaser's requirements during the development
 - handling of problems detected after acceptance including quality related claims and purchaser complaints
 - activities carried out by the purchaser, especially the purchaser role in requirements specification, installation and acceptance
 - facilities and tools to be provided by the purchaser
 - standards and procedures to be used

Requirements Specification

Quality
Manual
Example

- The supplier should have a complete, unambiguous set of functional requirements. In addition, these requirements should include all aspects necessary to satisfy the purchaser's need. These may include: performance, reliability, safety, security and privacy. These requirements should be stated precisely enough so as to allow validation during product acceptance.

Requirements Specification

Quality
Manual
Example

- The following items are frequently found to be relevant in the requirements specification:
 - a) assignment of persons on both sides responsible for establishing the Purchaser's Requirements Specification
 - b) methods for agreeing on requirements and approving changes
 - c) efforts to prevent misunderstandings such as definitions of terms, explanations of background of requirements
 - d) recording and reviewing discussion results on both sides

Development Planning

Quality
Manual
Example

- The development plan should cover the following:
 - a) a definition of the project in terms of a disciplined process including a statement of its objectives
 - b) the organisation of the project resources
 - c) the project phases
 - d) the project schedule identifying the tasks to be performed, resources and time required for each and relationships between tasks
 - e) identification of related plans

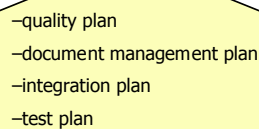

- quality plan
- document management plan
- integration plan
- test plan

Development Plan

Quality
Manual
Example

- The phases covered by the development plan should include design, implementation, testing and validation, acceptance, maintenance.
- The development plan should be:
 - reviewed and approved before execution;**
 - updated as development progresses.**
- Progress reviews should be held and documented.
- The inputs and outputs to each phase should be defined and documented.

Quality Plan

- Associated with each Development Plan the supplier should prepare and document a Quality Plan which should specify or reference:
 - a) quality objectives, expressed in measurable terms
 - b) identification of types of test, verification and validation activities together with the methods and tools to be employed
 - c) defined entry and exit criteria for each development phase
 - d) detailed planning of test verification and validation activities to be carried out including schedules, resources and approval authorities
 - e) specific responsibilities for quality activities

such as:

- inspections, reviews and tests
- document management
- defect control and corrective action

Other Areas

- Other areas to which attention should be paid and which are not phase dependent are:
 - document management and control
 - measurement
 - rules, practices and conventions
 - purchasing
 - training

QFD = Quality-Function Deployment

- QFD is a quality assurance technique developed in Japan that helps to ensure that the voice of the customer - the specific needs and desires of a given customer segment - is clearly heard in the development and deployment of a product or service.

now used by...

AT&T, IBM, Ford, GM,
Chrysler, Hewlett
Packard, DEC, ITT

Strategic Concepts

- QFD is based on 4 strategic concepts
 - preservation of the voice of the customer
 - input to product realisation from a cross-functional team
 - supports concurrent engineering by allowing planning for implementation phases to start early
 - graphical display

Traditional Product Realisation

- each work group has its own ideas and methods
- product realisation is highly sequential
- many development iterations are necessary
- design characteristics stray from customer intent
- everything is important
- designs meet tolerances not targets

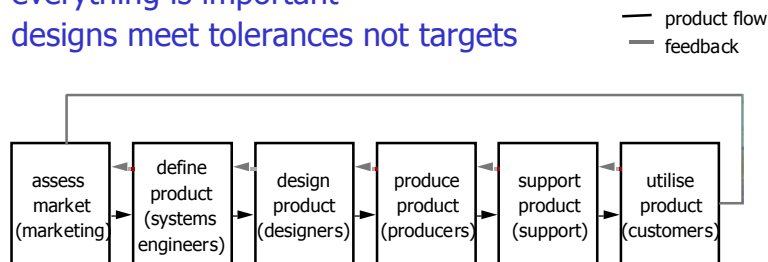

QFD Approach

- cross functional teams build a common understanding of the product
- product realisation more concurrent
- little requirement for rework
- voice of customer preserved in the design characteristics
- only those attributes that are key to customer satisfaction are important
- designs meet explicit operating targets not theoretical specification tolerances

QFD Approach

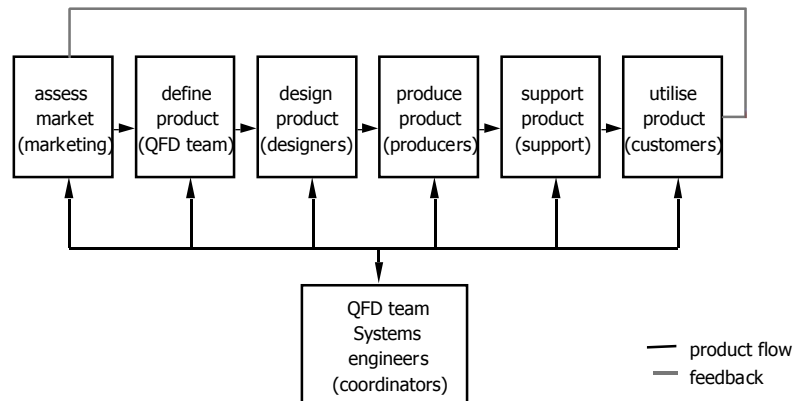

The Team

- representatives of each major work group
- empowered to make decisions
- meet regularly
- operate by consensus, supported by facilitator

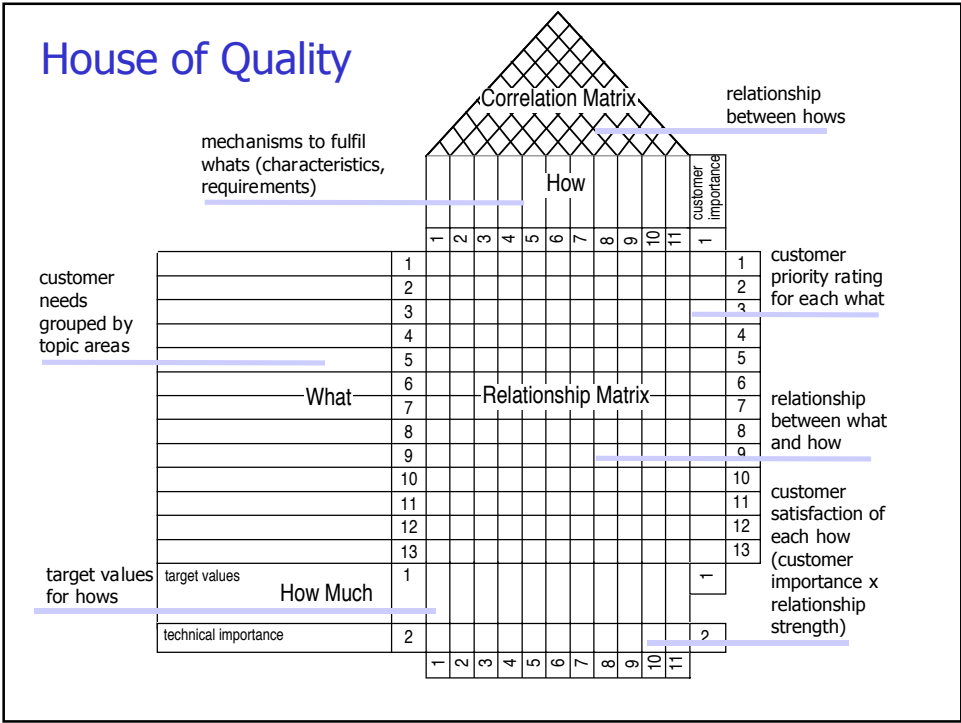

- ## Relationships
- What vs How
 - Strong Relationship ● 9
 - Medium Relationship ○ 3
 - Weak Relationship △ 1
 - How vs How
 - Strong Positive ●
 - Positive ○
 - Negative X
 - Weak negative ✕

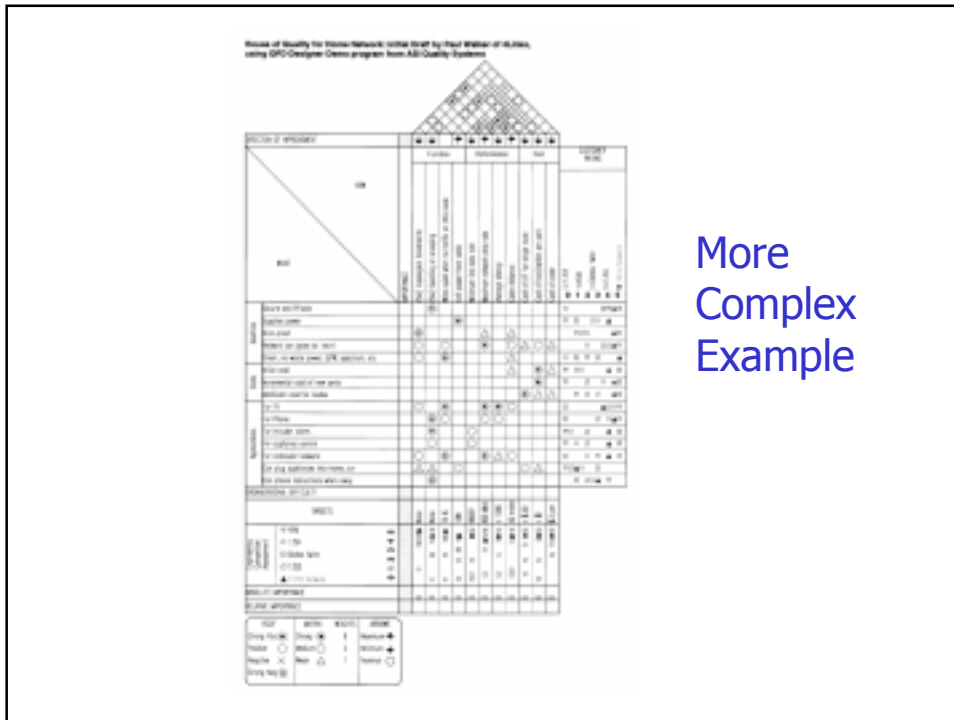

The Process

- 1) organise the project
- 2) gather and organise customer wants (WHATS)
- 3) establish mechanisms and target values
- 4) establish relationships
- 5) evaluate the HOWS
- 6) analyse HOQ and finalise target values

Analysis

- sanity checks
 - empty rows (unfulfilled needs)
 - empty columns (unneeded mechanisms)
 - HOW x HOW correlation (interaction of mechanisms)
 - % of cells filled in relationship matrix

Using QFD

- to integrate QFD with organisation:
 - keep gathering the voice of the customer
 - refer continually to the house-of-quality matrix as guide for organisation
 - link target values with internal process-management metrics
 - revisit QFD process each time strategic decisions are considered

Refinements - Phased QFD

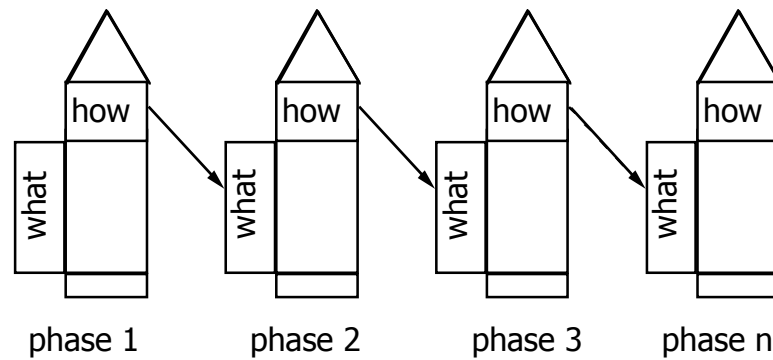

Other Matrices

- customer wants vs functions
- function vs cost
- customer wants vs cost
- technical characteristics vs functions
- ...and so on

Applications...

- QFD can be used:
- for a new product
- for a new service
- for an existing product
- for an existing service
- for "enterprise planning"
- for process management
- in reverse for technology-driven engineering

Key Points

- Quality is the key to successful software development. To achieve quality in a software product or service requires planning, analysis and control of quality at every stage in development
- To do this quality management system must be developed and documented. This system and its development should itself be subject to analysis and control procedures.
- QFD is a simple and practical tool for ensuring consideration of the customer throughout the process. It makes quality issues explicit and provides a reference point for tracing these issues.